

Owners Manual MAX-11A1 mk2 Upper Receiver



LAGE Manufacturing, L.L.C. 916 E. Baseline Rd. STE #113 Mesa, AZ 85204

CM11A1-300

NFA Warning

This upper receiver is designed to be used with the SWD M-11A1 and RPB M-11A1 .380 ACP submachine gun. NFA (National Firearms Act, Title 26, United States Code) rules apply to its use and possession.

It is the owners/users responsibility to comply with all local, State and Federal laws and regulations in the use of this product.

Description/Features

The MAX-11A1 mk2 Upper Receiver is designed to provide additional capability to the SWD M-11A1 .380 ACP submachinegun.

The MAX-11A1 mk2 is available in either .380 ACP (MAX-11A1/380 mk2) or 9mm (MAX-11A1/9 mk2).

Utilizing a bolt weight, the rate of fire is reduced to around 700 rounds per minute, for the .380 ACP MAX-11A1/380 mk2 and to around 950 RPM with the 9mm MAX-11A1/9 mk2. This allows easy controllability of fire and the ability to consistently fire single and two round bursts from the automatic setting.

The MAX-11A1 mk2 attaches to the stock M-11A1 lower receiver without any modification to the lower receiver.

Features:

- 1) Top Rail 10-1/2"
- 2) Bottom Rail 3"
- 3) Side Accessory Rail Mounting Points
- 4) Cocking Handle (reciprocating)
- 5) 8 -3/8 inch barrel length, removable (threaded 1/2-28)
- 6) Flash Hider

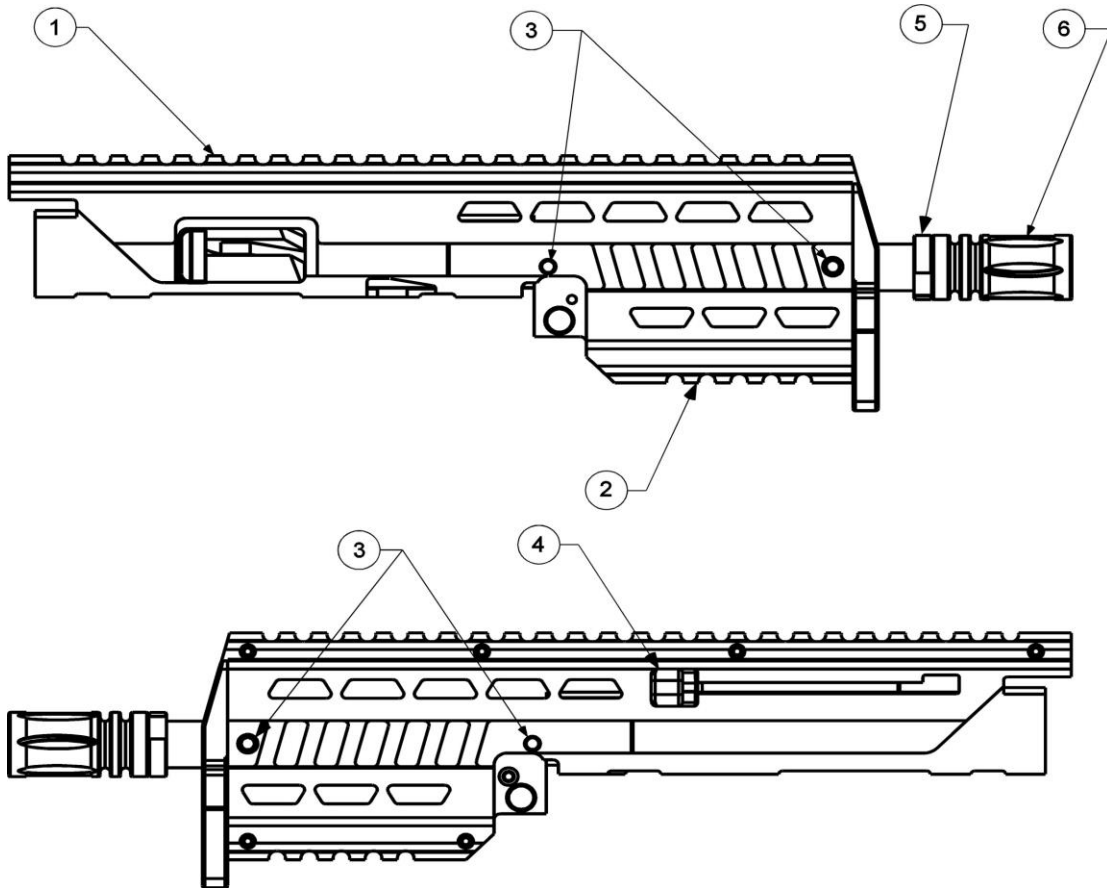

Installation

- ① Insure firearm is unloaded. Point in a safe direction. Remove magazine and pull bolt to the rear to insure chamber is empty.



- ② While holding cocking knob, pull trigger and ease bolt forward into closed position.



- ③ Remove front retaining pin and detach upper receiver from lower receiver.



- ④ Install Cocking Knob. Retract bolt until slot in bolt aligns with the rear of the slot in the upper receiver. Slide in cocking knob until it seats. Slide bolt and cocking knob forward.



- ⑤ Slide rear of upper receiver assembly into rear of lower receiver until receiver holes align.



- ⑥ Install your retaining pin.



Removal

- ① Point firearm in a safe direction and insure it is unloaded and magazine is removed.
- ② Remove front retaining pin.



- ⑤ Remove upper receiver from lower receiver.



Operation

CAUTION!

The MAX-11A1/380 mk2 comes standard with a bolt assembly and barrel for use with .380 ACP ammunition.

The bolt assembly and barrel have the bullet caliber marked on them as shown below.



The MAX-11A1/9 mk2 comes standard with a bolt assembly and barrel for use with 9mm ammunition.

The bolt assembly has the bullet caliber marked on it as shown below.
The barrel is not marked with the caliber.



Make sure the correct bolt assembly and barrel is installed for the ammunition you will be using.

Ammunition

The MAX-11A1/380 mk2 is designed to use 90 to 95 grain .380 ACP full metal jacket, round nose ammunition. Recommended ammunition manufacturer is Magtech.

The MAX-11A1/9 is designed to use 115 grain 9mm full metal jacket, round nose ammunition. Recommended ammunition manufacturer are Federal, CCI (Blazer Brass) or S&B.

Cocking

Pull cocking knob to rear and release. Bolt will remain open.
Cocking knob will remain in rear position.



Upper Scope/Optics Rail

A full length rail for mounting a scope or other aiming device is located on the top of the upper receiver. The profile of the rail is a standard Mil-Std-1913 style and will accept Weaver or Mil-Std-1913 scope rings or mounting systems.



Lower Accessory Rail

A rail for attaching a front hand grip, laser aiming device, tactical flashlight or other device is attached to the bottom of the front handgrip.

Please note, some hand grips are not manufactured to the correct dimensions to mount on a Mil-Std-1913 rail. Insure the grip is correct before attaching. The recommended front grip is our Forward Canted K-Grip.

Additionally, tactical flashlights designed for use with pistol accessory rails will fit on the accessory rail but will be a tighter fit.



Side Accessory Rails (optional)

The MAX-11A1 mk2 can be fitted with left and right side accessory rails for mounting additional accessories. The optional accessory rails come with mounting screws. When installing the new screws, use Loctite 242 on the threads.



Attachment of other muzzle devices

The barrel is threaded 1/2-28. The flash suppressor is torqued to 25 foot/pounds and secured with Loctite Threadlocker 242. A lockwasher is intentionally not used in order to insure the mounting surface of the barrel remains square and burr free for optional use with a suppressor. If you choose to replace the flash suppressor with another type of muzzle device, insure it is designed for use with 9mm caliber bullets.

To prevent marring of the finish, apply masking tape to the flats on the barrel end and the flash suppressor. To remove the flash suppressor, attach a 3/4" open end wrench to the wrench flats on the barrel. Attach a second 3/4" open end wrench to the wrench flats on the flash suppressor. While holding the wrench attached to the barrel stationary, rotate the wrench attached to the flash suppressor counter-clockwise.



Attachment of a Sound Suppressor

A sound suppressor may be attached to the MAX-11A1 mk2 by removing the flash suppressor. The threads on the MAX-11A1 mk2 barrel are 1/2-28. A thread adapter can be used to couple suppressors with other thread sizes or mounting systems. Most commonly, a 1/2-28 to 5/8-11 thread adapter is required to use the suppressor that mates to the stock SWD M-11A1. When using the suppressor with the thread adapter, regularly tighten the suppressor to the thread adapter. It will have a tendency to loosen during firing. This is typical of the 5/8-11 mounting thread and is not related to the design of the MAX-11A1 mk2 upper receiver.

Remove the flash suppressor per the above procedure and install the thread adapter per the manufacturers' instructions. The recommended supplier for thread adapters is TROS.

CAUTION: Due to the possible variance in the concentricity and squareness of the combined barrel, thread adapter and suppressor you will be using, it is recommended that thread adapters be installed by a qualified gunsmith and the mounted suppressor be inspected for alignment prior to firing. Additionally, some suppressor manufacturers' warranties expressly require that they thread the barrel for the firearm that their suppressor will be used on. The warranty for the MAX-11A1 mk2 applies only to the upper receiver assembly and not any accessories subsequently attached by the Customer.

Removal of Barrel

The barrel has been designed to allow easy removal and installation. There are 3/4" wrench flats at the muzzle end.

To prevent marring the finish of the upper receiver use a padded vise or hard wood inserts. Clamp the front sides of the upper behind the front cover mounting screws. Using a 3/4" open end wrench on the wrench flats at the muzzle end, turn the wrench counter clockwise to loosen and remove barrel. To re-install barrel, apply Loctite Threadlocker 242 to the barrel threads and insert barrel into trunnion. Hand thread barrel and tighten by turning the wrench clockwise. Use a torque wrench to tighten to 40 foot/pounds.



Cleaning, Lubrication and Maintenance

NOTE:

The MAX-11A1 mk2 upper receiver halves are secured together with screws. These are not intended to be removed for routine maintenance and cleaning.

Cleaning and lubrication should be carried out per the original manual provided with the SWD M-11A1 with the following additional requirements:

Recommended cleaning interval is after each shooting session or 500 rounds of use.

Remove the upper receiver from the lower receiver. Slide the bolt assembly fully rearward. Remove the cocking knob from the left side of the receiver. Remove bolt assembly from upper receiver.

Clean upper receiver with solvent. The metal finish is resistant to most cleaning chemicals including Mineral Spirits, Acetone and MEK. Inspect all mounting screws for tightness.

Clean barrel using your preferred method.

Lightly coat all surfaces with gun oil. Wipe away any excess oil.

Clean the bolt assembly in solvent. Brush the bolt face and breach area with a nylon or brass brush to remove any built-up carbon deposits. Insure the bolt face is clean and free of debris.

Using a fingertip, apply a thin coat of gun oil to the bolt surfaces. Wipe away any excess oil. Add a drop of gun oil to the recoil spring where it meets the back of the bolt. Inspect the sear engagement surface for rounding or burrs. Small burrs may be removed with a file. If the surface is worn and preventing the sear from reliably engaging, discontinue use and have it repaired immediately.

Insert the bolt assembly into the upper receiver. Slide bolt assembly forward until slot in bolt assembly lines up with rear of slot in upper receiver. Install cocking knob and push bolt assembly forward. Re-install upper receiver to lower receiver.

Parts Replacement

The MAX-11A1 mk2 Upper Receiver uses some parts that are common to the original SWD M-11A1. All replacement parts can be purchased from LAGE Manufacturing, L.L.C.. Additionally, you can purchase the following parts from any company that sells parts for the SWD M-11A1:

- Buffer
- Back Plate
- Recoil Rod
- Extractor Spring*
- Extractor Roll Pin*

* Removal and installation requires removal of the bolt weight from the bolt.

Referenced Manufacturers

Loctite Threadlocker 242

Loctite is a trademark of Loctite Corp, 1001 Trout Brook Crossing
Rocky Hill, CT 06067

TROS

PO Box 680

Clackamas, OR 97015

www.trosusa.com

Warranty and Repair

WARRANTY

Note: Use of reloaded/remanufactured ammunition or steel or aluminum cased ammunition will void your warranty

The MAX-11A1 mk2 Slowfire Upper Receiver has been manufactured in a manner to insure it is defect free and durable.

LAGE Manufacturing, L.L.C. warrants to the original purchaser that this product is free from defects in materials and workmanship for the period of One Year from the original date of purchase. This warranty does not apply to damage due directly or indirectly, to misuse, abuse, negligence or accidental, repairs or alterations outside our facilities or to lack of maintenance. We shall in no event be liable for death, injuries to persons or property or for incidental, contingent, special or consequential damages arising from the use of this product. The above limitation of exclusion may be subject to state law and may not apply to you.

To utilize this warranty, the MAX-11A1 mk2 Slowfire Upper Receiver must be returned to us packaged in a manner to preclude damage during transit and with shipping charges prepaid. Proof of purchase date, and a written description of the complaint must be included. If upon inspection, the complaint is verified, we will either repair or replace the product at our election or we may elect to refund the purchase price if we cannot readily and quickly provide a replacement. We will return the repaired product at our expense, but if we determine that there is no defect, or that the defect was a result of causes not within the scope of this warranty, then you must bear the cost of returning the product.

This warranty gives you specific legal rights and you may have other rights, which vary from state to state.